

GB

03

PORTABLE COMPRESSORS

The right solution for any application

⇒ C14 – C270TS-9

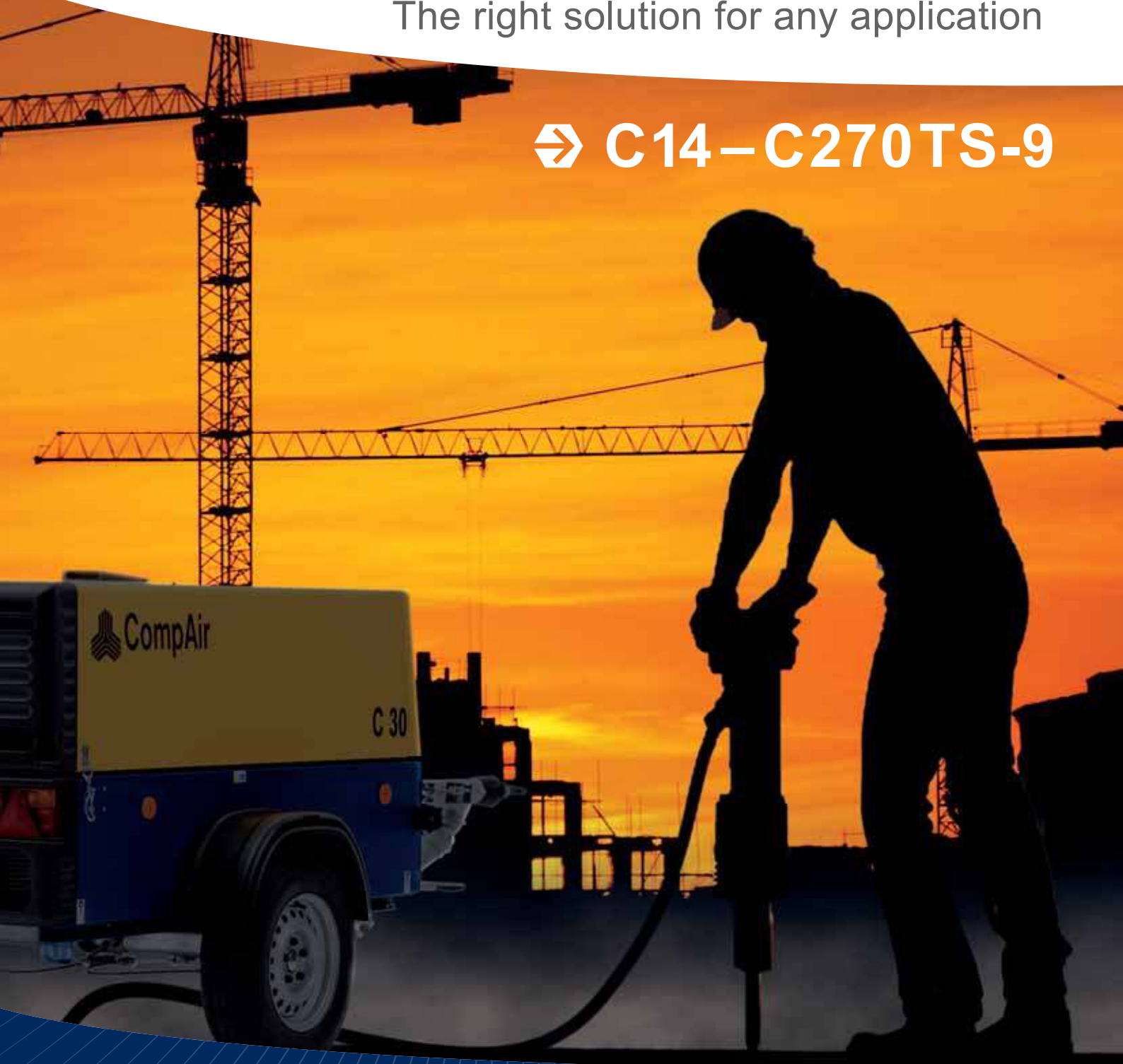

INTELLIGENT AIR TECHNOLOGY

C10-12 – C14

⇒ 1.0 to 1.4 m³/min

Product range DLT 0101

C10-12 – C14 is a powerful alternative to electrical tools. Small, compact and lightweight, at only 142 kg weight with 1.0–1.4 m³/min at 7–12 bar. Perfect for a wide-range of repair and installation jobs.

⇒ **Honda GX 610V**
air cooled petrol engine



⇒ **Manual and electric start**

with two starting options as standard, these compressors are easy to use in all conditions

C20 – C30

⇒ 2.0 to 3.0 m³/min

Product range DLT 0206

This range has the output to run up to two breakers and are driven by quiet-running energy efficient Kubota engines. With the benefit of a wide engine speed range, fuel savings are increased and the engine reliability and life time are enhanced. The various applications of these compressors can be further enhanced by integrated generators, which can supply power for the site, lighting and electrical tools. With an operating weight of less than 500 kg (unbraked) the compressor can be transported by small vehicles.

⇒ **Kubota D1105/D1505**

reliable, energy efficient diesel engine

⇒ **Soft start**

extends the engine life time by reducing engine stress during start-up and allowing the engine to reach running temperature with the compressor unloaded

⇒ **Robust plastic protection**

protects the control panel and lighting elements



⇒ **Bolted single sheets**

the steel canopy is mass galvanised and electrostatically coated, offering excellent protection against damage and corrosion. With bolted single sheets, exchange is both quick and easy. Plastic canopy is available as an option.

⇒ **Easy access hinged hood**

with two robust gas struts, the hood is light and easy to open, offering excellent accessibility for easy maintenance

⇒ **Transparent plastic fuel tank**

extremely robust, the plastic fuel tank allows direct visual level indication and contamination checks to be carried out in seconds

⇒ **Progressive volume flow regulation**

engine speed and air intake regulation are automatically adapted to compressed air requirement

⇒ **Air end with spin-on oil filter cartridge**

for quick and easy maintenance

⇒ **Internal main switch board**

to avoid unauthorised operation

⇒ **Central lifting eye**

for easy handling by crane

⇒ **Operational reliability**

designed for – 10 to + 50° C ambient temperature

Portable-Control 1

⇒ **Fully protected digital display**

with tamper proof hour counter

⇒ **Automatic protection in case of malfunction:**

- Compressor temperature too high
- Engine oil pressure too low
- Engine temperature too high
- Battery voltage too low
- Fuel level too low

⇒ **Indication lamps** for automatic emergency stop in case of malfunction.

⇒ **Start by rotary switch** to avoid loss of time caused by lost ignition key.



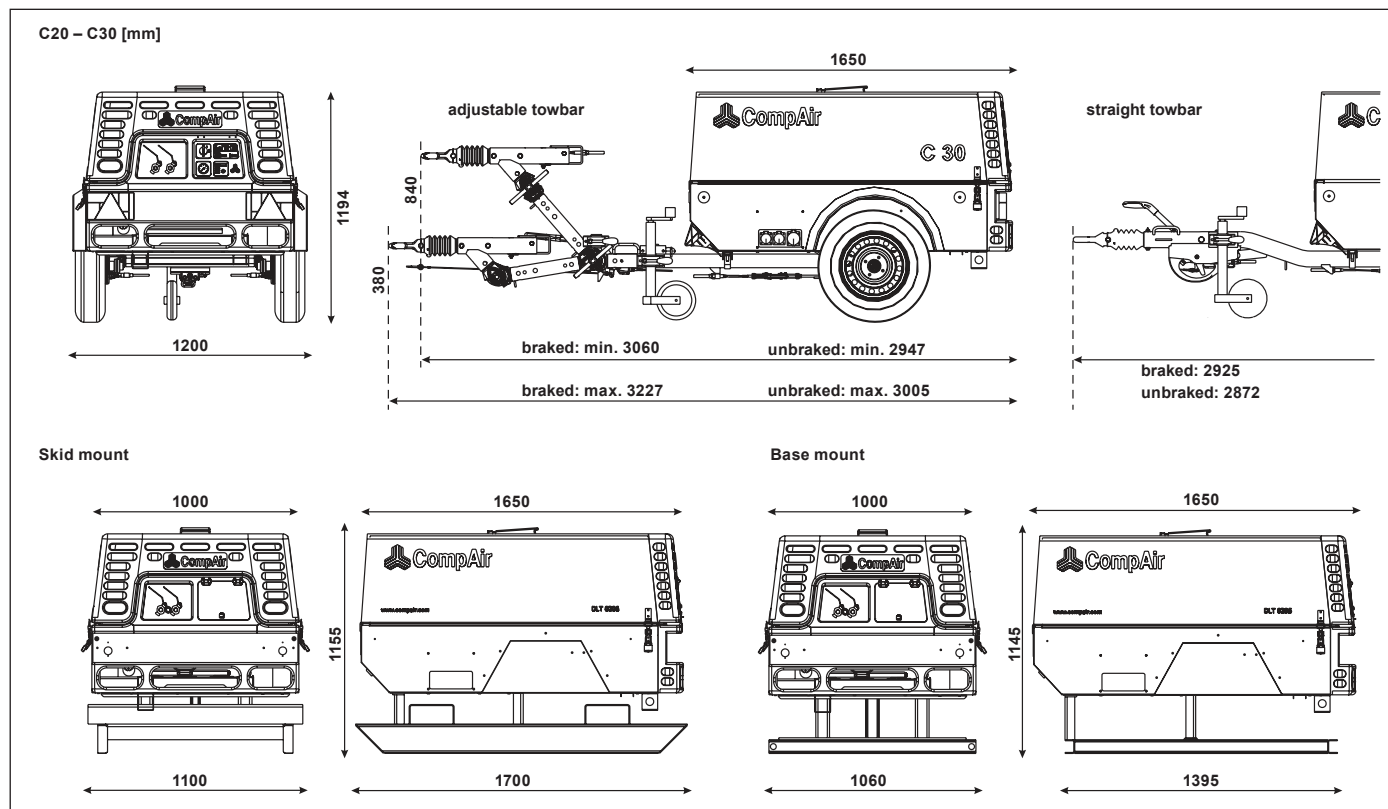

AirPlus options on fold out page →

Product range	DLT 0101			DLT 0206							
	C10-12	C12-10	C14	C20	C20GS	C25	C25-10	C30	C30G		
Operational data											
Volume flow ¹⁾	m ³ /min	1.0	1.2	1.4	2.0	2.0 ²⁾	2.5	2.5	3.0	3.0 ²⁾	
Operating pressure	bar	12	10	7	7	7	7	10	7	7	
Compressed air outlets		1 x 3/4"			2 x 3/4"						
Engine		Honda GX610V-Twin			Kubota D1105	Kubota D1505	Kubota D1105	Kubota D1505			
Installed engine power	kW	13.2	13.2	13.2	16.3	23.1	19.4	23.1	23.1	23.1	
Engine off load speed	1/min	2200	2200	2200	2000	2000	2000	2000	2000	2000	
Engine full load speed	1/min	2900	2900	2900	2600	2600	2600	2600	2600	2600	
Fuel tank capacity	l	20	20	20	40	40	40	40	40	40	
Operating weight³⁾											
Portable compressor	manually transportable	kg	160	160	160	–	–	–	–	–	
	adjustable towbar braked	kg	–	–	–	580	658	586	610	610	658
	adjustable towbar unbraked	kg	–	–	–	539	617	545	570	570	617
	straight towbar braked	kg	–	–	–	558	636	564	588	588	636
	straight towbar unbraked	kg	–	–	–	528	606	534	558	558	606
Base mount		kg	–	–	–	458	535	463	485	485	535
Skid mount		kg	–	–	–	498	575	503	525	525	575
Dimensions											
Length	adjustable towbar braked	mm	–	–	–	3169–3227	3169–3227	3169–3227	3169–3227	3169–3227	3169–3227
	straight towbar braked	mm	–	–	–	2925	2925	2925	2925	2925	2925
Width		mm	700	700	700	1200	1200	1200	1200	1200	1200
Height		mm	630	630	630	1194	1194	1194	1194	1194	1194
Length of canopy		mm	1010	1010	1010	1650	1650	1650	1650	1650	1650
Sound level											
Power sound level ⁴⁾	dB(A) LWA		97	97	97	97	98	98	98	98	98
Pressure sound level ⁵⁾	dB(A) LPA		69	69	69	69	69	69	69	69	69

¹⁾ Acc. to ISO 1217 Ed. 4 2009 Annex D

²⁾ 9 kVA generator (C20GS max. 6 kVA)

³⁾ Operating weight without options

⁴⁾ Legal limiting values of EC directive acc. to 2000/14/EC

⁵⁾ Noise level acc. to PNEUROP PN8NTC2.2 at 7 m

C35-10 – C50

⇒ 3.5 – 5.0 m³/min

Product range DLT 0408

The highly successful CompAir range C35-10 – C50 is driven by very quiet-running, water-cooled Yanmar 4TNV88BKCP 4-cylinder diesel engines. The compressor is particularly suitable for applications in cities and built-up areas, where stringent restrictions are set on noise emissions. The light construction of under 750 kg (C38 and C42) makes the compressor suitable for many different applications and is therefore ideal for use by hire companies. These compact and lightweight compressors are available with various chassis and also with the option of integrated generator or aftercooler or both.

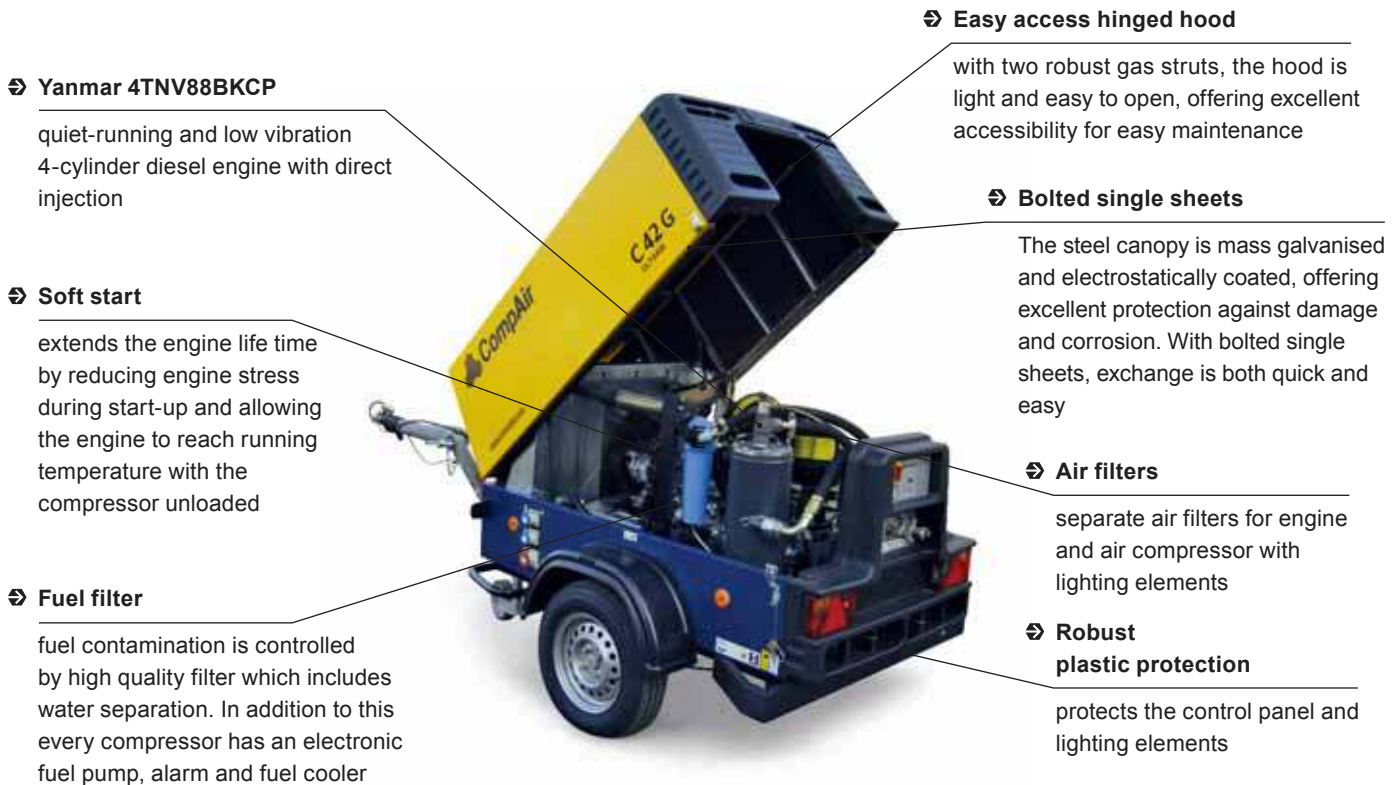

- ⇒ **Progressive volume flow regulation**
engine speed and air intake regulation are automatically adapted to compressed air requirement
- ⇒ **Air end with spin-on oil filter cartridge**
for quick and easy maintenance
- ⇒ **Transparent plastic fuel tank**
allows direct visual level indication and quick contamination checks
- ⇒ **Central lifting eye**
for easy handling by crane
- ⇒ **Operational reliability**
designed for – 10 to + 50° C ambient temperature
- ⇒ **Compressor oil temperature regulating valve**
ensures safe operation of compressor at low ambient temperatures or extreme partial load. Standard!
- ⇒ **Internal main switch** avoids unauthorised operation



Portable-Control 2

- ⇒ **Fully protected digital display** with tamper proof hour counter
- ⇒ **Automatic protection in case of malfunction:**
 - Compressor temperature too high
 - Engine oil pressure too low
 - Engine temperature too high
 - Rotational speed too low
 - Battery voltage too low
 - Fuel level too low
 - Cooling water too low
- ⇒ **Indication lamps** for
 - Preheat
 - Operation
 - Automatic emergency stop after malfunction
- ⇒ **Start by rotary switch** to avoid loss of time caused by lost ignition key

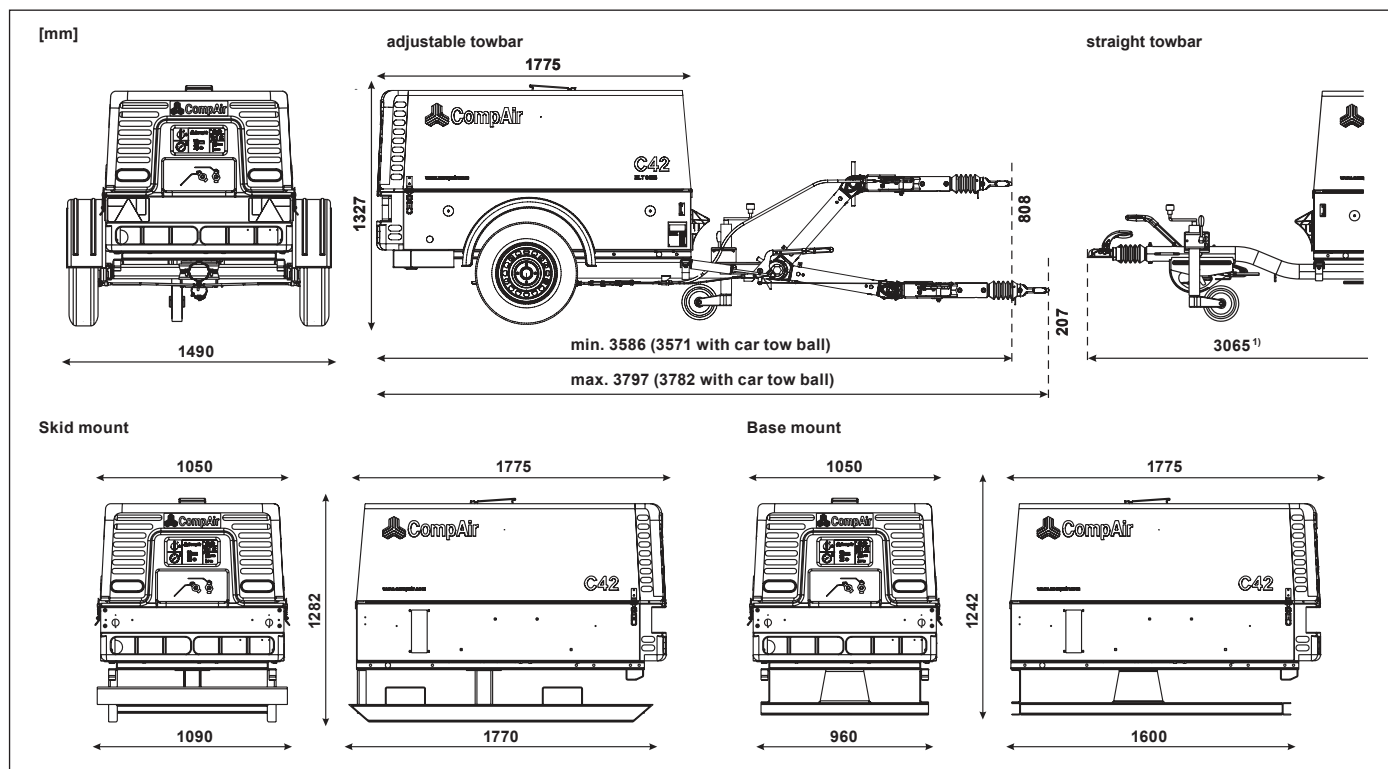

AirPlus
options
on fold
out page
→

Product range		DLT 0408				
Type		C35-10	C38	C42	C50	
Operational data						
Volume flow ¹⁾ (Optional 9 or 15 kVA Generator)	m ³ /min	3.5	3.8	4.2	5.0	
Operating pressure	bar	10	7	7	7	
Compressed air outlet		2 x 3/4"				
Engine						
Yanmar 4TNV88BKCP						
Installed engine power	kW	35.0	35.0	35.0	35.0	
Engine off load speed	1/min	1600	1600	1600	1600	
Engine full load speed	1/min	2800	2800	2800	2800	
Fuel tank capacity	l	60	60	60	60	
Operating weight²⁾						
Portable compressor	adjustable towbar braked	kg	810	810	810	866
	adjustable towbar unbraked	kg	745	745	745	–
	straight towbar braked	kg	775	775	775	835
	straight towbar unbraked	kg	740	740	740	800
Base mount	kg	685	685	685	780	
Skid mount	kg	740	740	740	800	
Dimensions						
Length	adjustable towbar braked	mm	3586 - 3797	3586 - 3797	3586 - 3797	3586 - 3797
	straight towbar braked	mm	3065	3065	3065	3065
Width	mm	1490	1490	1490	1490	
Height (adjustable towbar, braked)	mm	1327	1327	1327	1327	
Length of canopy	mm	1775	1775	1775	1775	
Sound level						
Power sound level ³⁾	dB(A) LWA	98	98	98	98	
Pressure sound level ⁴⁾	dB(A) LPA	69	69	69	69	

¹⁾ Acc. to ISO 1217 Ed. 4 2009 Annex D

²⁾ Operating weight without options

³⁾ Legal limiting values of EC directive acc. to 2000/14/EC

⁴⁾ Noise level acc. to PNEUROP PN8NTC2.2 at 7 m

C55-14 – C76

⇒ 5.5 – 7.6 m³/min

Product range DLT 0704

These proven and tested compressors stand out for their low fuel consumption and high efficiency. Thanks to a wide pressure range up to 14 bar, this compact compressor range is extremely versatile and meets many requirements of numerous applications. The compressors have enough storage capacity for two hammers, picks or any other pneumatic tools. Separate engine and compressor air filters guarantee a long service life. All of the service points are strategically located for easy access.



- ⇒ **Progressive volume flow regulation**
engine speed and air intake regulation are automatically adapted to compressed air requirement
- ⇒ **Air end with spin-on oil filter cartridge**
for quick and easy maintenance
- ⇒ **Transparent plastic fuel tank**
allows direct visual level indication and quick contamination checks
- ⇒ **Central lifting eye**
for easy handling by crane
- ⇒ **Operational reliability**
designed for – 10 to + 50°C ambient temperature
- ⇒ **Compressor oil temperature regulating valve**
ensures safe operation of compressor at low ambient temperatures or extreme partial load



Portable-Control 2

- ⇒ **Fully protected digital display** with tamper proof hour counter
- ⇒ **Automatic protection in case of malfunction:**
 - Compressor temperature too high
 - Engine oil pressure too low
 - Engine temperature too high
 - Battery voltage too low
 - Fuel level too low
- ⇒ **Indication lamps** for automatic emergency stop in case of malfunction
- ⇒ **Start by rotary switch** to avoid loss of time caused by lost ignition key
- ⇒ **Internal main switch** avoids unauthorised operation

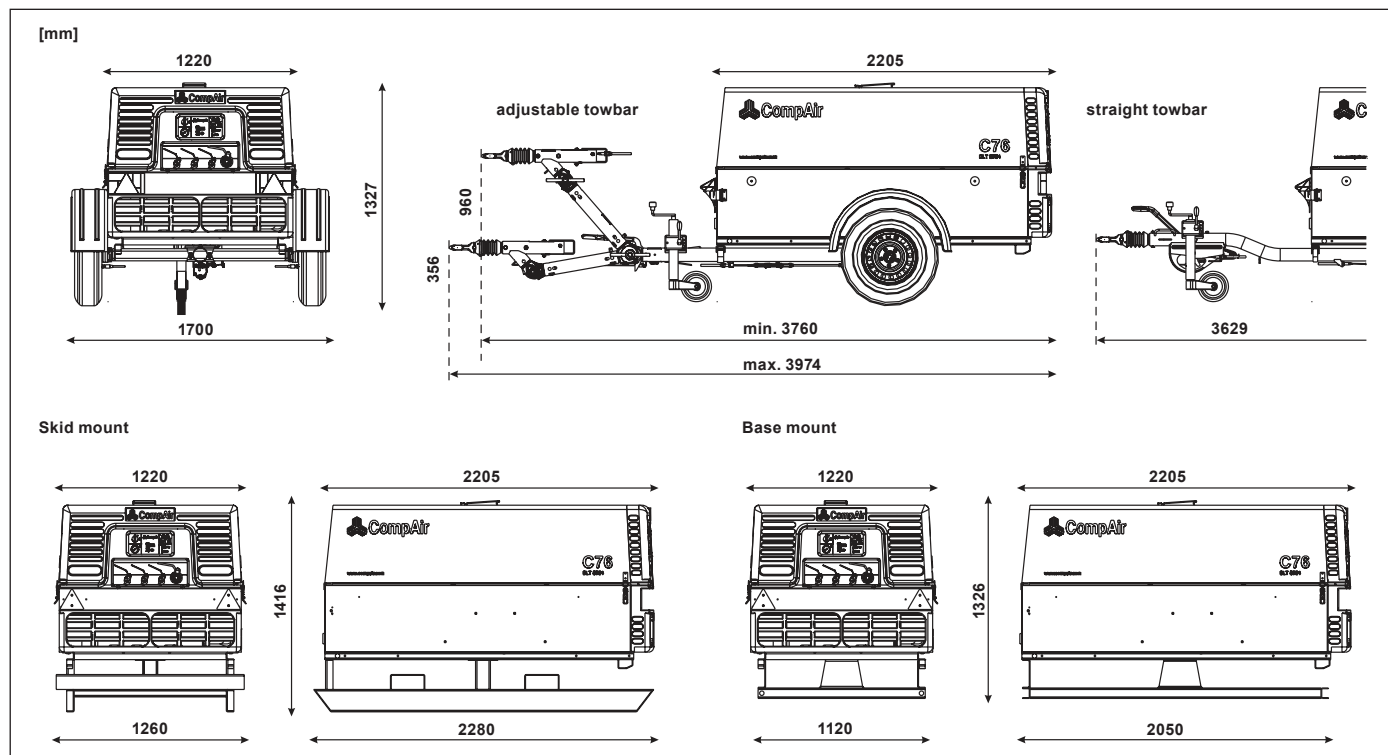

Product range		DLT 0704				
Type		C55-14	C60-12	C65-10	C65HS	C76
Operational data						
Volume flow ¹⁾ (Optional 9 or 15 kVA Generator)	m ³ /min	5.5	6.0	6.5	6.5	7.6
Operating pressure	bar	14	12	10	7	7
Compressed air outlet		3 x 3/4" + 1 x 1 1/2"				
Engine						
Cummins B3.3 TAA						
Installed engine power	kW	63	63	63	63	63
Engine off load speed	1/min	1600	1600	1600	1600	1600
Engine full load speed	1/min	2600	2600	2600	2600	2600
Fuel tank capacity	l	140	140	140	140	140
Operating weight²⁾						
Portable compressor	adjustable towbar braked	kg	1200	1200	1200	1200
	straight towbar braked	kg	1160	1160	1160	1160
Base mount	kg	1070	1070	1070	1070	1070
Skid mount	kg	1100	1100	1100	1100	1100
Dimensions						
Length	adjustable towbar braked	mm	3760–3974	3760–3974	3760–3974	3760–3974
	straight towbar braked	mm	3629	3629	3629	3629
Width	mm	1700	1700	1700	1700	1700
Height	mm	1440	1440	1440	1440	1440
Length of the canopy	mm	2205	2205	2205	2205	2205
Sound level						
Power sound level ³⁾	dB(A) LWA	99	99	99	99	99
Pressure sound level ⁴⁾	dB(A) LPA	71	71	71	71	71

¹⁾ Acc. to ISO 1217 Ed. 4 2009 Annex D ²⁾ Operating weight without options ³⁾ Legal limiting values of EC directive acc. to 2000/14/EC
⁴⁾ Noise level acc. to PNEUROP PN8NTC2.2 at 7 m

 AirPlus options on fold out page →

C85-14 – C140-9

⇒ 8.5 – 14.0 m³/min

Product range DLT 1303

Designed for the toughest site conditions, whether it's for road building, civil engineering or restoration work, this range of compressors offers outstanding reliability, performance and compressed air quality, with fully accessible doors maintenance is also made easy. The compressor as standard is equipped with numerous options, offering a substantial cost saving to the customer. Thanks to the inclusion of two batteries reliable running and performance can be achieved even in the coldest winter. The long life cycle of these compressors is further enhanced by additional engine management protection. Diesel engines from the QSB 4.5 range from Cummins, a world leader in diesel engine production, are fitted with electronic fuel injection to meet all the European standards with regards to exhaust emissions for the coming years.

⇒ Cummins QSB 4.5

quiet-running and low vibration 4-cylinder diesel engine

⇒ Soft start

extends the engine life time by reducing engine stress during start-up and allowing the engine to reach running temperature with the compressor unloaded

⇒ Fuel filter

fuel contamination is controlled by high quality filter which includes water separation. In addition to this every compressor has a manual fuel pump as standard



⇒ Easy access side wing doors

offering excellent accessibility for easy maintenance

⇒ 24 V electric system

ensures sufficient power reserves in case of cold starts and a safe run-up ability

⇒ Air filters

separate air filters for engine and air compressor

⇒ Robust plastic protection

protects the control panel and lighting elements

⇒ Progressive volume flow regulation

engine speed and air intake regulation are automatically adapted to compressed air requirement

⇒ Air end with spin-on oil filter cartridge

for quick and easy maintenance

⇒ Compressor oil temperature regulating valve

ensures safe operation of compressor at low ambient temperatures or extreme partial load

⇒ Central lifting eye

for easy handling by crane

⇒ Operational reliability

designed for – 10 to +50 °C ambient temperature

⇒ Sheet steel fuel tank

with direct visual level indication



Portable-Control 3

⇒ Digital display

all the necessary operation data at a glance

⇒ Quick and easy pressure setting

⇒ Automatic protection in case of malfunction:

- Engine oil pressure too low
- Cooling water temperature too high
- Intercooler temperature too high
- Airend temperature too high
- Engine Cooling water level too low
- Fuel level too low
- Water in fuel pre filter
- Load control (v-belt break, alternator defect)
- Hardware errors

⇒ Fault memory with detailed operating data

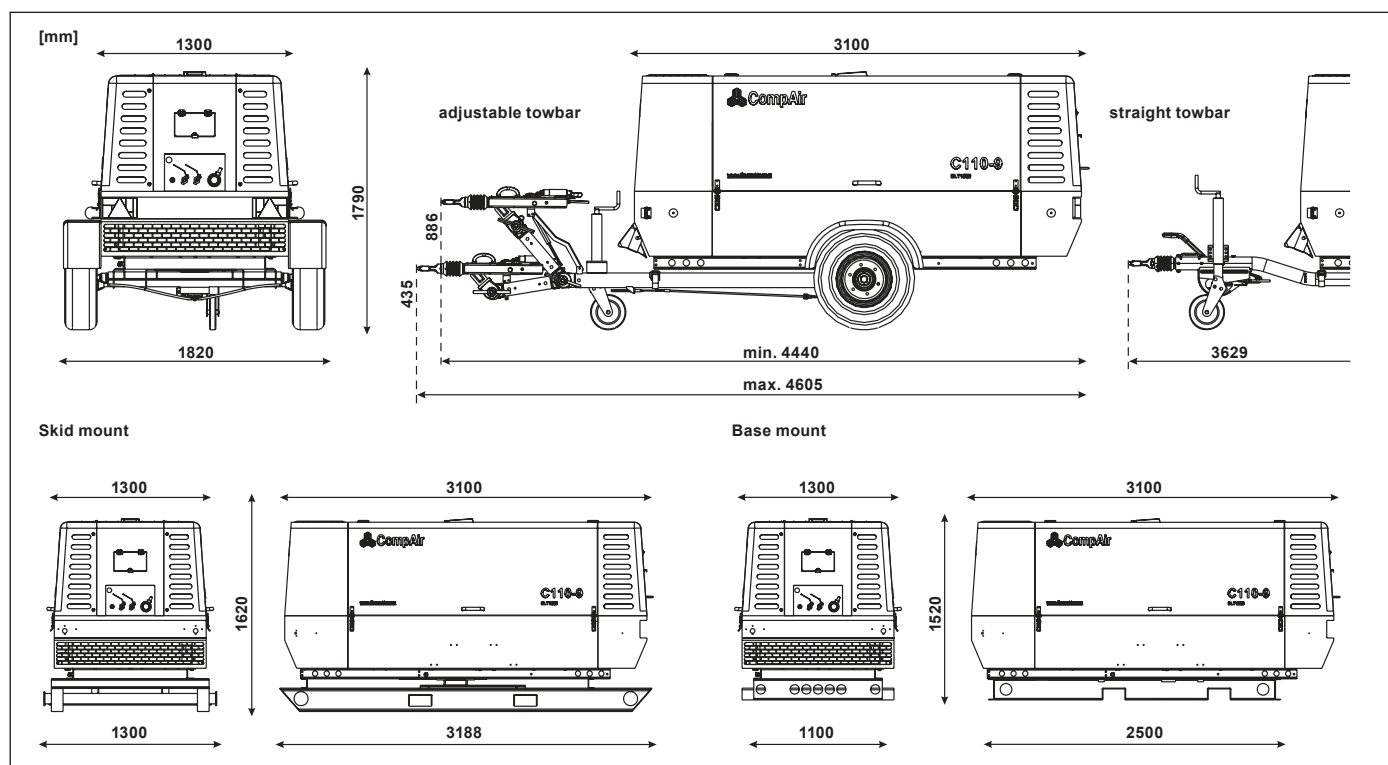

Product range		DLT 1303						
Type		C85-14	C95-12	C110-9	C125	C105-14	C115-12	C140-9
Operational data								
Volume flow ¹⁾	m ³ /min	8.5	9.5	11.3	12.5	10.5	11.5	13.3
Operating pressure	bar	14	12	8.6	7	14	12	8.6
Compressed air outlet		2 x 3/4" and 1 x 2"						
Engine		Cummins QSB 4.5						
Installed engine power	kW	97	97	97	97	119	119	119
Engine off load speed	1/min	1300	1300	1300	1300	1300	1300	1300
Engine full load speed	1/min	2300	2300	2300	2300	2200	2200	2200
Fuel tank capacity	l	210	210	210	210	210	210	210
Operating weight²⁾								
Portable compressor	adjustable towbar braked	kg	1980	1980	1980	1980	1980	1980
	straight towbar braked	kg	1950	1950	1950	1950	1950	1950
Base mount	kg	1810	1810	1810	1810	1810	1810	1810
Skid mount	kg	1920	1920	1920	1920	1920	1920	1920
Dimensions								
Length	adjustable towbar braked	mm	4440–4605	4440–4605	4440–4605	4440–4605	4440–4605	4440–4605
	straight towbar braked	mm	3629	3629	3629	3629	3629	3629
Width	mm	1820	1820	1820	1820	1820	1820	1820
Height	mm	1790	1790	1790	1790	1790	1790	1790
Length of the canopy	mm	3100	3100	3100	3100	3100	3100	3100
Sound level								
Power sound level ³⁾	dB(A) LWA	99	99	99	99	99	99	99
Pressure sound level ⁴⁾	dB(A) LPA	70	70	70	70	70	70	70

¹⁾ Acc. to ISO 1217 Ed. 4 2009 Annex D

²⁾ Operating weight without options

³⁾ Legal limiting values of EC directive acc. to 2000/14/EC

⁴⁾ Noise level acc. to PNEUROPN8NTC2.2 at 7 m

C200TS-24 – C270TS-9

⇒ 20.0 – 27.0 m³/min

Product range DLT 2701



Patented bi-turbo technology = Low cost of ownership! A radical new approach to energy conservation.

The CompAir TurboScrew patented bi-turbo technology makes these compressors outstanding in their class. On average site conditions where the demand varies between idle, part load and full load, the TurboScrew consumes up to **30% less fuel** than most of the conventional compressors on the market.

TurboScrew Technology

CompAir's TurboScrew compression system is a radical new approach to energy conservation. It uses a Cummins turbo assisted engine powering a CompAir screw compressor unit with the addition of an engine exhaust gas drive turbine, pre-compressing the suction inlet air before it enters the compression chamber.

PATENTED

⇒ Easy access side wing doors

offering excellent accessibility for easy maintenance

⇒ Cummins QSB 6.7

robust 6-cylinder turbo-charged diesel engine with an additionally integrated second turbo-charger for the pre-compression of the inlet air of the compressor.



**UP TO
24
BAR**

⇒ 24 V electric System

ensures sufficient power reserves in case of cold starts and a safe run-up ability

⇒ Bolted single sheets

The steel canopy is mass galvanised and electro-statically coated, offering excellent protection against damage and corrosion. With bolted single sheets, exchange is both quick and easy

⇒ Soft start

extends the engine life time by reducing engine stress during start-up and allowing the engine to reach running temperature with the compressor unloaded

⇒ Small footprint & one of the lightest in class

The lightweight TurboScrew compressors can be towed by a vehicle with a maximum towing weight of 3500kg and is great for getting to hard-to-access sites.

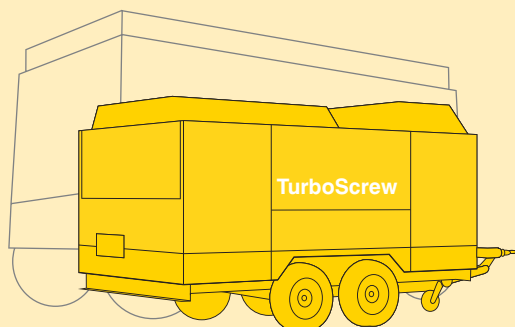

⇒ Potential Fuel Savings

Based on average site running conditions, over lifetime of 10,000 hours, fuel savings of up to 30% can be achieved when compared with equivalent conventional compressors of this output range. This represents up to 20% of total lifetime costs.

Your benefit: significant cost savings!

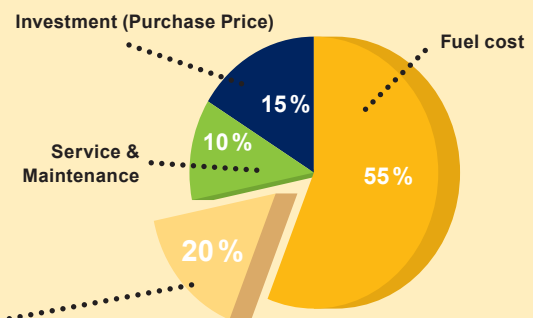

TurboScrew fuel savings = 20% of lifetime cost

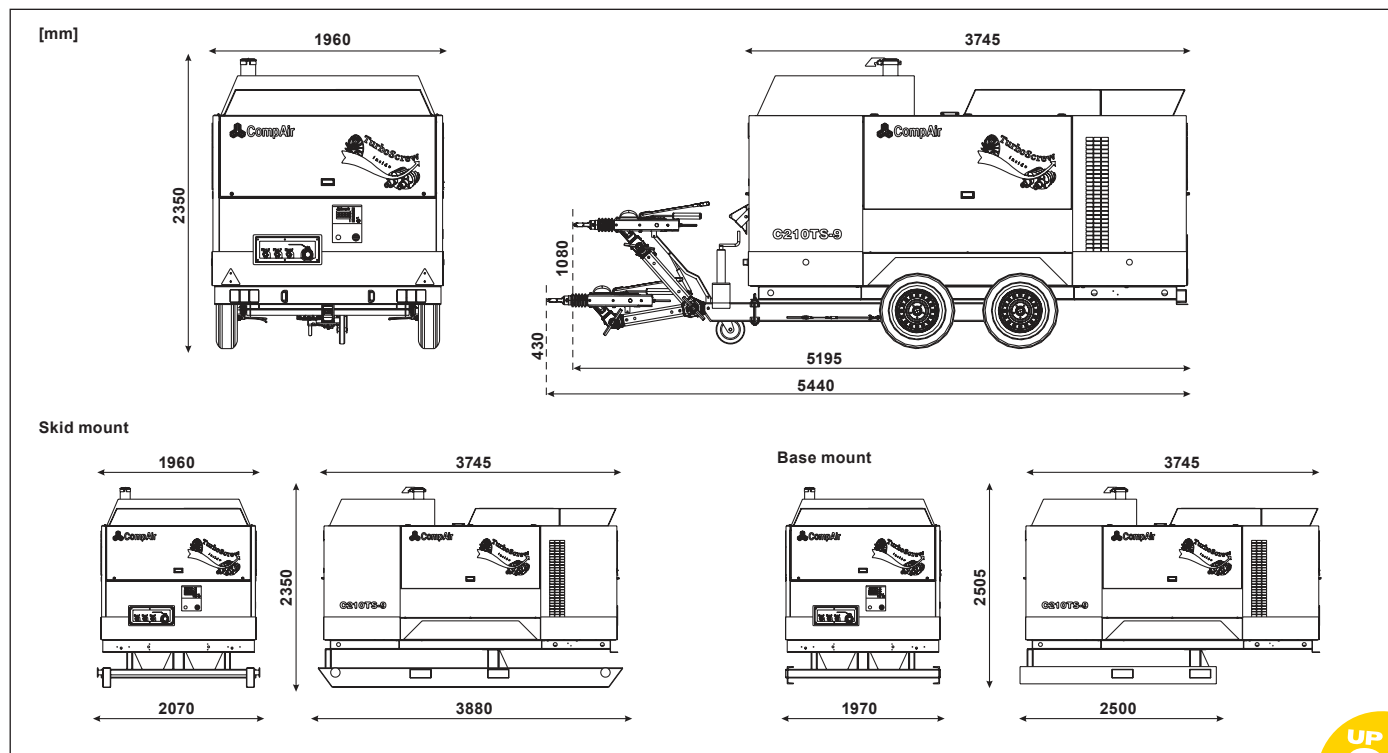

Product range	DLT 2701									DLT 2701		
Type	C200TS-14	C210TS-12	C220TS-10	C230TS-9	C240TS-14	C250TS-12	C260TS-10	C270TS-9	C200TS-24	C210TS-21	C230TS-17	
Operational data												
Volume flow ¹⁾	m ³ /min	20	21	22	23	24	25	26	27	20	21	23
Operating pressure	bar	14	12	10	9	14	12	10	9	24	21	17
Compressed air outlet	3 x 3/4" and 1 x 2"									1 x 2"		
Engine	Cummins QSB 6.7											
Installed engine power	kW	180	180	180	180	228	228	228	228	228	228	228
Engine off load speed	1/min	1000	1000	1000	1000	1000	1000	1000	1000	1000	1000	1000
Engine full load speed	1/min	2400	2400	2400	2400	2400	2400	2400	2400	2400	2400	2400
Fuel tank capacity	l	370	370	370	370	370	370	370	370	370	370	370
Operating weight²⁾												
Portable compressor adjustable towbar braked	kg	3310	3310	3310	3310	3340	3340	3340	3340	3350	3350	3350
Skid mount	kg	3370	3370	3370	3370	3400	3400	3400	3400	3410	3410	3410
Base mount	kg	3210	3210	3210	3210	3240	3240	3240	3240	3250	3250	3250
Dimensions												
Length	mm	5195-5440	5195-5440	5195-5440	5195-5440	5195-5440	5195-5440	5195-5440	5195-5440	5195-5440	5195-5440	5195-5440
Width	mm	1960	1960	1960	1960	1960	1960	1960	1960	1960	1960	1960
Height	mm	2350	2350	2350	2350	2350	2350	2350	2350	2350	2350	2350
Length of the canopy	mm	3750	3750	3750	3750	3750	3750	3750	3750	3750	3750	3750
Sound level												
Power sound level ³⁾	dB(A) LWA	100	100	100	100	100	100	100	100	100	100	100
Pressure sound level ⁴⁾	dB(A) LPA	71	71	71	71	71	71	71	71	71	71	71

¹⁾ Acc. to ISO 1217 Ed. 4 2009 Annex D

²⁾ Operating weight without options

³⁾ Legal limiting values of EC directive acc. to 2000/14/EC

⁴⁾ Noise level acc. to PNEUROP PN8NTC2.2 at 7 m

AirPlus ➔ Many options for many applications

Options for all types of C14 to C270TS-9

✦ Optional ✓ Standard - Not available

Type	Compressed Air Quality				Compressor Equipment					Integrated Generator				Engine Accessories		
	Aftercooler	Filtration	Oiler	Separate air connection with ISO 8573.1, class 1_1	Tool-Box	Hose reel	Bundled bottom box	Plastic canopy	Oil thermostatic valve	6 kVA at 110V 50Hz	7 kVA at 110V 50Hz	9kVA/16Amp max. at 230/400V 50Hz	15kVA/16Amp max. at 230/400V 50 Hz	Diesel filter with water separator	Spark arrester	Engine shutdown at overspeed from flammable gases
DLT 0101																
C10-12	-	-	+	-	-	-	-	-	-	-	-	-	-	-	-	-
C12-10	-	-	+	-	-	-	-	-	-	-	-	-	-	-	-	-
C14	-	-	+	-	-	-	-	-	-	-	-	-	-	-	-	-
DLT 0206																
C20	+	-	+	+	+	+	+	+	+	+	-	+	-	✓	+	+
C25	+	-	+	+	+	+	+	+	+	-	-	-	-	✓	+	+
C30	+	-	+	+	+	+	+	+	+	+	-	+	-	✓	+	+
DLT 0407																
C35-10	+	+	+	+	+	✓	-	-	✓	-	+	+	+	✓	+	+
C38	+	+	+	+	+	✓	-	-	✓	-	+	+	+	✓	+	+
C42	+	+	+	+	+	✓	-	-	✓	-	+	+	+	✓	+	+
C50	+	+	+	+	+	✓	-	-	✓	-	+	+	+	✓	+	+
DLT 0704																
C55-14	+	+	+	+	+	+	+	-	✓	-	+	+	+	✓	+	+
C60-12	+	+	+	+	+	+	+	-	✓	-	+	+	+	✓	+	+
C65-10	+	+	+	+	+	+	+	-	✓	-	+	+	+	✓	+	+
C76	+	+	+	+	+	+	+	-	✓	-	+	+	+	✓	+	+
DLT 1303																
C85-14	+	+	+	+	-	-	-	-	✓	-	-	-	-	✓	+	-
C95-12	+	+	+	+	-	-	-	-	✓	-	-	-	-	✓	+	-
C110-9	+	+	+	+	-	-	-	-	✓	-	-	-	-	✓	+	-
C125	+	+	+	+	-	-	-	-	✓	-	-	-	-	✓	+	-
C105-14	+	+	+	+	-	-	-	-	✓	-	-	-	-	✓	+	-
C115-12	+	+	+	+	-	-	-	-	✓	-	-	-	-	✓	+	-
C140-9	+	+	+	+	-	-	-	-	✓	-	-	-	-	✓	+	-
DLT 2701																
C200TS-14	+	+	-	-	-	-	-	-	✓	-	-	-	-	✓	+	-
C210TS-12	+	+	-	-	-	-	-	-	✓	-	-	-	-	✓	+	-
C220TS-10	+	+	-	-	-	-	-	-	✓	-	-	-	-	✓	+	-
C230TS-9	+	+	-	-	-	-	-	-	✓	-	-	-	-	✓	+	-
C240TS-14	+	+	-	-	-	-	-	-	✓	-	-	-	-	✓	+	-
C250TS-12	+	+	-	-	-	-	-	-	✓	-	-	-	-	✓	+	-
C260TS-10	+	+	-	-	-	-	-	-	✓	-	-	-	-	✓	+	-
C270TS-9	+	+	-	-	-	-	-	-	✓	-	-	-	-	✓	+	-
C200TS-24	-	-	-	-	-	-	-	-	✓	-	-	-	-	✓	+	-
C210TS-21	-	-	-	-	-	-	-	-	✓	-	-	-	-	✓	+	-
C230TS-17	-	-	-	-	-	-	-	-	✓	-	-	-	-	✓	+	-

➔ Integrated Generator

- Electronically controlled synchronous generator
- Protection IP 54

➔ Electronic Controller

- Insulation monitoring
- Output voltage regulation

- Temperature regulation limit

- Two-mode switch – constant and variable motor speed



AirPlus ➔ Many options for many applications

Options for all types of C14 to C270TS-9



Breakers



Sand-blasting



Ice-blasting



Drillings



Concrete spraying

➔ Schematic display of all available air treatment options

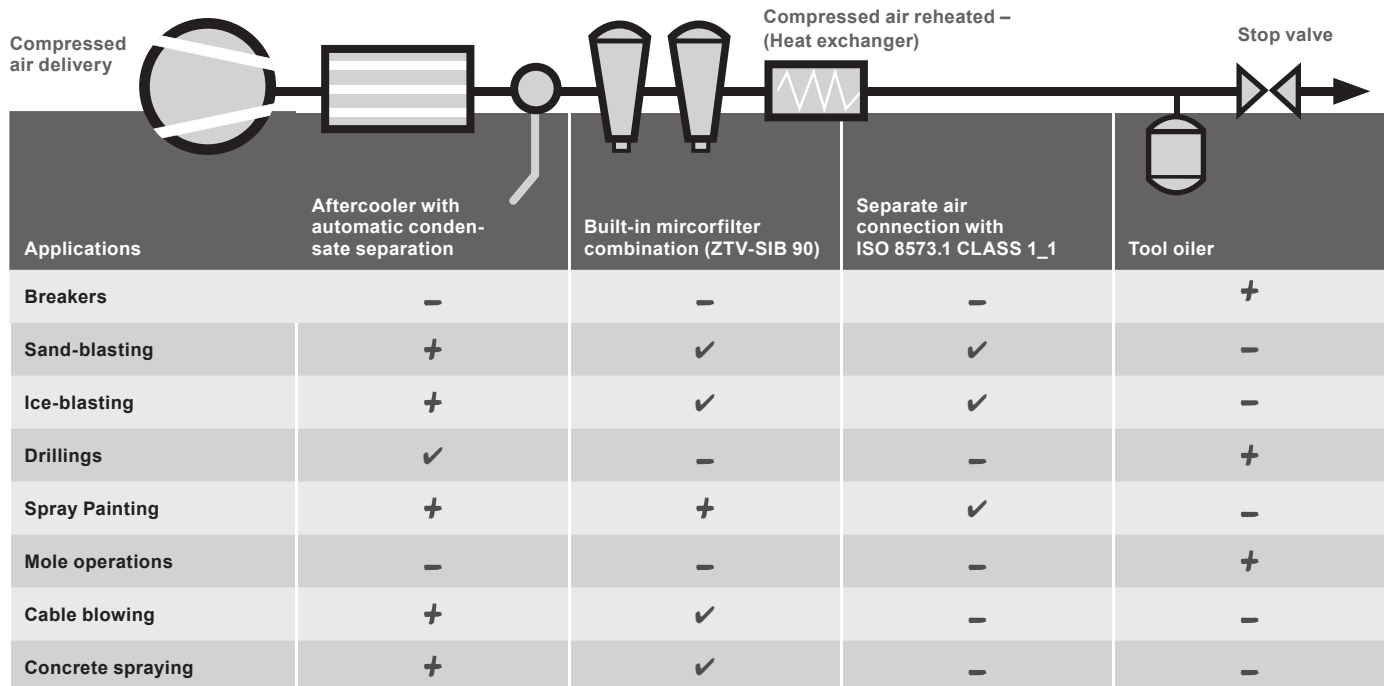

+ recommended ✓ depending on manufacturer and application - not needed

Built-in aftercooler with automatic water separation. Reduces water content in the compressed air. An additional heat exchanger uses compressor oil to heat the compressed air which protects the tools from freezing.

Built-in microfilter combination

(in addition to above mentioned aftercooler) Air treatment with microfilters according to ISO 8573.1 standards including ZTV-SIB 90 with residual oil content of < 0.01 ppm.



Hose reel
with 20 m light self-supporting hose; protects the air hose and enables fast set up of tools at site



Robust plastic canopy C20 – C50
also available as a retrofit kit



Compressor oil temperature regulating valve
ensures safe operation of compressor at low ambient temperatures. Prevents compressed air tools from freezing.
Standard from C50

Air & Plus

Special paint colour and labelling to customer specification
Provides distinctive site identity and assists in traceability in the event of loss or theft

INNOVATIVE PRODUCTS AND SERVICES – TRUST COMPAIR TO SUPPLY INTELLIGENT COMPRESSED AIR SOLUTIONS.



➤ Portable Compressors

C14 – C270TS-9
1 to 27 m³/min
from 7 to 24 bar

Air Plus offers many variations and options:

- Aftercooler
- Ultra-fine filters
- Integrated generator
- Bunded bottom box
- Hose reel
- Exhaust spark arrestor
- Exhaust gas particulate filter
- Customer colours

Turboscrew Technology
C200TS-24 – C270TS-9
up to 30% less diesel fuel consumption

PATENTED

➤ Generator

ADG28 – ADG132
28 – 132 kVA

Variants & Options:

- Sockets
- Terminal strip
- Chassis up to 50 mile/hour
- Customer colours

➤ Tools

- Chipping Hammers
- Rockdrills
- Pickhammers
- Breakers

Vibration damped tools:

- Rockdrills
- Pickhammers
- Breakers

Accessories:

- Large selection of pointed chisel, slat chisel and spade
- In line lubricator
- Water separator with or without oiler
- Air hoses

➤ Services

- Technical support and advice
- Worldwide service network
- Reliable supply of spare parts
- Individual customer solutions
- Seminars and trainings

CompAir policy is one of continuous improvement and we therefore reserve the right to alter specifications and prices without prior notice. All products are sold subject to the Company's conditions of sale.

